

1U Equipment Installation guide for CM Bracket

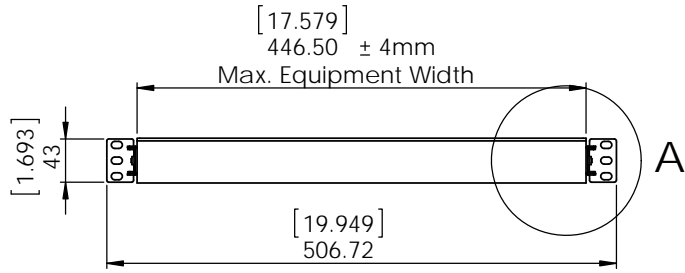

Align open slots with your equipment's mounting holes on each side

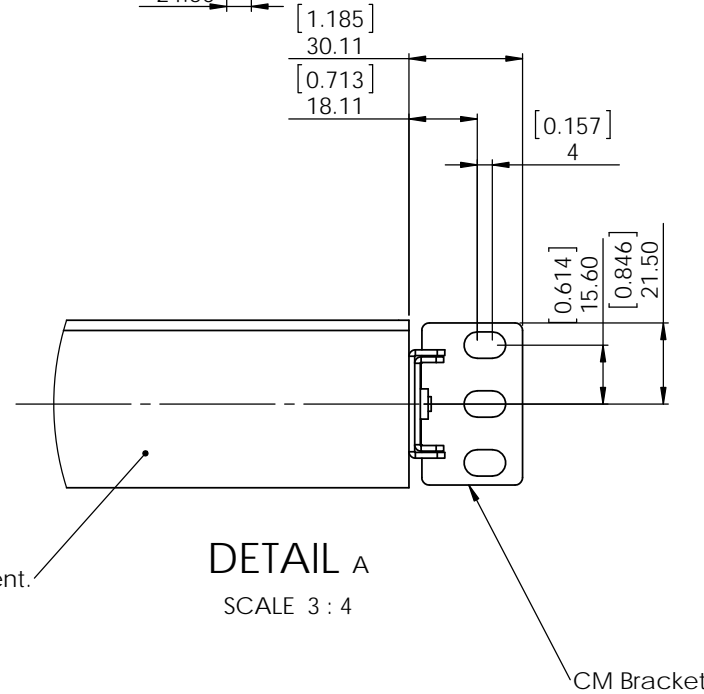
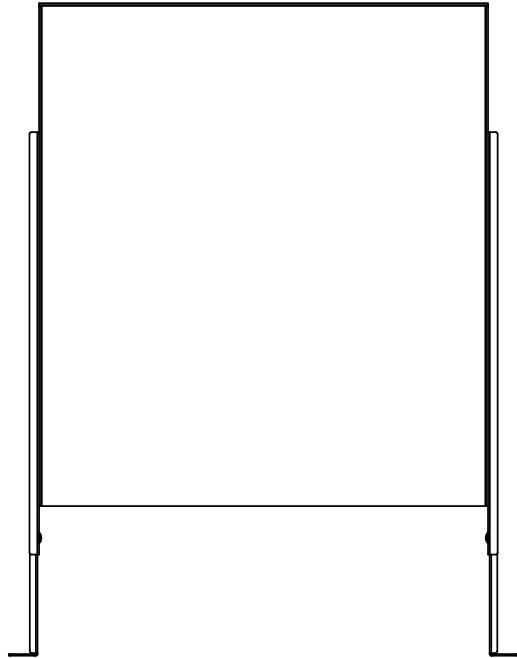
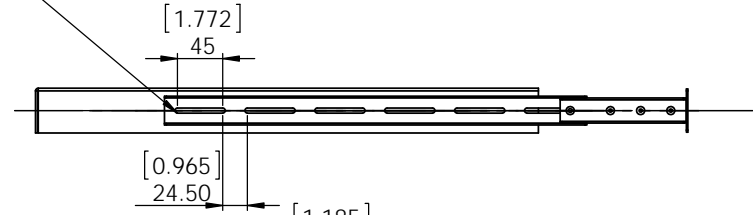

DETAIL A  
SCALE 3 : 4

Note:  
1. No sharp edges.  
2. RoHS: Manufacturer must ensure that all components used must comply with RoHS Regulation.

CONFIDENTIAL DOCUMENT DO NOT COPY

**Industrial Automation & Enclosures**  
A leading developer of industrial rackmount products  
TEL:(516)997-5050 FAX:(516)997-5784  
©2016 IAE Inc /www.iaenclosures.com

PROJECT NO.	CM-BRACKET	DRAWN		MATERIAL	Gauge	UNSPECIFIED TOLERANCES: ±0.15
MODEL		APPV'D		FINISH	Zinc / Chrome	
PART NO.		DATE	4/12/2016	SCALE	1:10	SHEET 1 OF 1
PART NAME	Installation Requirements	REVISION	V 1.0	PROJECTION	Third Angle	UNIT:mm